



Transtank[®]
INTERNATIONAL

Operator's Product HandBook

Versatile Boom[™]



“HELPING TO DEVELOP AND PROTECT THE LAND”

Contents

| | |
|---------------------------------------|-------|
| Safety | 4 |
| General Safety Instructon | 5 |
| General Information | 6 |
| Description | 6 |
| Machine Limitations | 7 |
| Versatile Boom Operating Instructions | 7 |
| Before First Use | 7 |
| Installation | 8 |
| VersatileBoom Set up | 9 |
| VersatileBoom Calibration | 10 |
| VersatileBoom Operation | 14 |
| Clean-Up and Decontamination | 15 |
| Maintenance | 16 |
| Periodic Checks | 16 |
| Maintenance Schedule | 16 |
| Risk Assessment | 18 |
| Warranty | 19-20 |

Disclaimer

All information, illustrations, and specifications contained in this manual are based on the latest product information available at the time of this publication's printing. TransTank International (TTi) reserves the right to alter and substitute specifications and methods at any time, in line with our commitment to continuous improvement.

No patent liability is assumed with respect to the use of information contained within this manual. While every precaution has been taken in the preparation of this manual, TTi assumes no responsibility for errors or omissions.

Thank you for your purchase of a TTi VersatileBoom, which will provide many years of reliable service when operated and maintained in accordance with this manual.

The VersatileBoom is designed for mounting on to a vehicle such as a Utility Terrain Vehicle (UTV) or a trailer-mounted spray unit. The VersatileBoom can be used for everything from herbicide or pesticide spraying through to firefighting purposes.

The VersatileBoom unit is supplied complete, tested and ready to mount to your vehicle. TTi warrants that the VersatileBoom has been designed and built for its intended purpose as a water or pesticide/herbicide spray boom.

The owner is responsible to ensure that the equipment is operated in accordance with this manual, and with Australian WorkSafe requirements. TTi is not liable for any loss, injury or death resulting from the failure to observe all safe working regulations as required by law.

Included with your VersatileBoom is this Operator's Handbook, which includes the Warranty Registration Card, and the package of mounting hardware, nozzles and fittings for installation by the operator.

Safety

This manual is intended for use by personnel experienced in the use of this and similar equipment. Read and understand this manual before attempting to operate or perform routine maintenance on this equipment. Your safety is of prime priority.



A WARNING highlights an essential operating or maintenance procedure, practice, condition or statement, which, if not strictly observed, could result in injury or death of personnel, or long-term health hazards.



A CAUTION highlights an essential operating or maintenance procedure, practice, condition or statement, which, if not observed, could result in damage or destruction of equipment.



A NOTE highlights or clarifies an essential systems description, operating or maintenance procedure, condition or statement.

General Safety Instructions

1. This unit is designed and manufactured solely for the purpose of spraying herbicides and pesticides, or water for firefighting. Under no circumstances should it be used for any other purpose. It must never be used in conjunction with fuel or similar materials.
2. Only authorised and trained personnel are to operate this equipment. Operators must have read and fully understood this manual before operating the VersatileBoom.
3. Do not operate the VersatileBoom anywhere near bystanders, livestock, watercourses or any non-targeted vegetation that may be in danger from spray drift contamination.
4. Wind direction and speed must be taken into account, as windy conditions may endanger the operator or damage to adjacent non-target vegetation. Avoid spraying on hot and sunny days or when wind speed exceeds 6.5km/h.
5. Do not operate this equipment while under the influence of alcohol or any drugs that could impair your capabilities in any way.
6. Personal Protection Equipment (PPE) appropriate to the chemicals being used must be worn at all times when operating the VersatileBoom. As a minimum, the PPE should include coveralls, gloves and boots. A face shield and PVC apron are recommended depending on the task. It is recommended that the following documents should be read and understood by the operator:
 - Australian Standard for Chemical protective clothing AS3765
 - Australian Standard for Respiratory protection devices AS1715
7. Ensure the capacity of the vehicle is suitable for the loaded mass of the spray unit and VersatileBoom. Refer to the vehicle's operator manual for safe working loads, correct securing points and relevant safety instructions. Do not exceed the carrying and braking capacity as specified by the vehicle manufacturer.
8. The VersatileBoom must be securely mounted on the vehicle. Ensure all fasteners are tightened and secure before operation.
9. Do not disconnect any hoses, nozzles or filters while the equipment is operating. Disconnecting any components while under pressure may result in uncontrolled fluid discharge which may be hazardous.
10. At completion of the operation, switch the pump off and relieve any residual pressure by opening a spray boom valve or other device, such as a spray gun trigger.
11. At completion of the operation, decontaminate the VersatileBoom and spray system. Drain any residue chemicals and store in a sealed container. Flush the system with fresh water and dispose of any unwanted chemicals and tank rinse residue in accordance with current environmental and workplace health and safety regulations.
12. Any unauthorised modifications to this equipment may affect its function and create a serious safety risk. Any unauthorised modifications will void any warranty on the unit.

General Information

Description

The TTi VersatileBoom is designed to distribute herbicides, pesticides or water feed by a separately supplied fluid dispensing system. A typical example of a VersatileBoom fitment is shown at Figure 1, with the unit mounted on the rear of a Utility Terrain Vehicle (UTV) and fed by a TTi OnDeck spray unit.



Figure 1 – VersatileBoom mounted on UTV

Mounting the VersatileBoom to the vehicle or trailer can be achieved by bolting directly to the vehicle's frame with the supplied bolts (refer to Figure 2), or using the optional Hayman Reece Hitch-it attachment, refer to Figure 3. The optimum height is to have the spray nozzles 500mm above ground level.



Figure 2 – VersatileBoom – Direct Bolted Mounting



Figure 3 – VersatileBoom – Hyman Reece Hitch-it Mounting

The VersatileBoom has three adjustable centre nozzles and two off-centre end jets to provide a range of spray volumes and patterns, which can achieve up to a 4m width swath.

Machine Limitations

The VersatileBoom (and associated spray system) is subject to operating limitations. It is the operator's responsibility to ensure that this equipment is being operated safely and within these limitations.

VersatileBoom Operating Instructions

Before first use

Your VersatileBoom is delivered partially assembled and ready to be fitted onto the vehicle. Before use, it needs to be set up using the following instructions:

1. Complete the warranty registration online at www.tti.com.au/warranty-registration, or use the Warranty Registration Card at the back of this handbook.
2. Store this handbook in a safe and easily accessible place for future reference.



WARNING: The operator must fully understand all aspects of this handbook. Do not operate the VersatileBoom and associated spray system if you are unfamiliar with its operation until you have read this handbook.

3. Read and thoroughly understand this handbook, paying particular attention to all safety requirements, before using the VersatileBoom for the first time.
4. Check that all fittings, valves and hoses are secure following transit, and are not damaged in any way.

Installation

The VersatileBoom is fitted to its mounting vehicle and set up as follows:



CAUTION: The VersatileBoom must be securely mounted to the vehicle. Failure to do so may result in the unit falling off the moving vehicle. Warranty is conditional on the VersatileBoom being correctly mounted.

1. Open the package of mounting hardware, nozzles and fittings and separate all components so they can be easily selected when required in the following steps.
2. Mount the VersatileBoom onto the vehicle securely, depending on configuration, refer to Figure 2 and Figure 3. The optimum height is to have the spray nozzles 500mm above ground level. Ensure the securing bolts (supplied in the package) are tightened sufficiently.
3. Insert the two supplied endcaps into the top of the VersatileBoom's two mounting frame arms, refer to Figure 4.

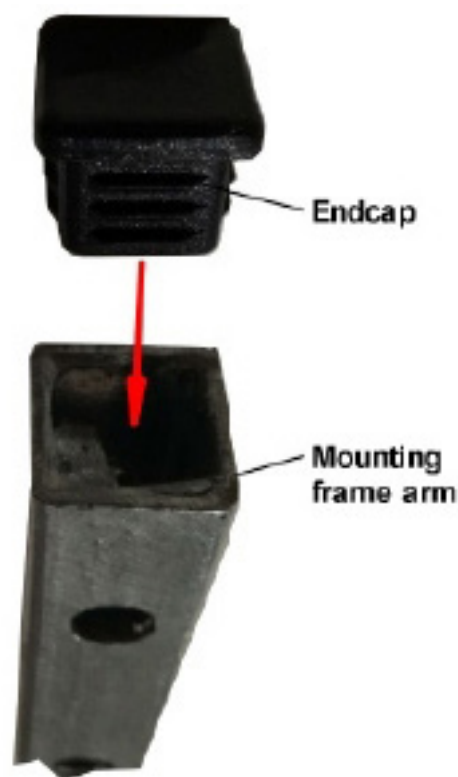

Figure 4 – VersatileBoom mounting frame endcaps

VersatileBoom Set up



NOTE: Ensure the pump system is switched off and depressurised when connecting the supply hose.

1. Connect the supply hose to the discharge port of the spray pump or delivery hose. Ensure the spray system's pump is switched off or isolated when connecting the VersatileBoom's supply hose.
2. For one of the outlet ports of the three adjustable nozzles, insert the filter into the port body as shown in Figure 5.

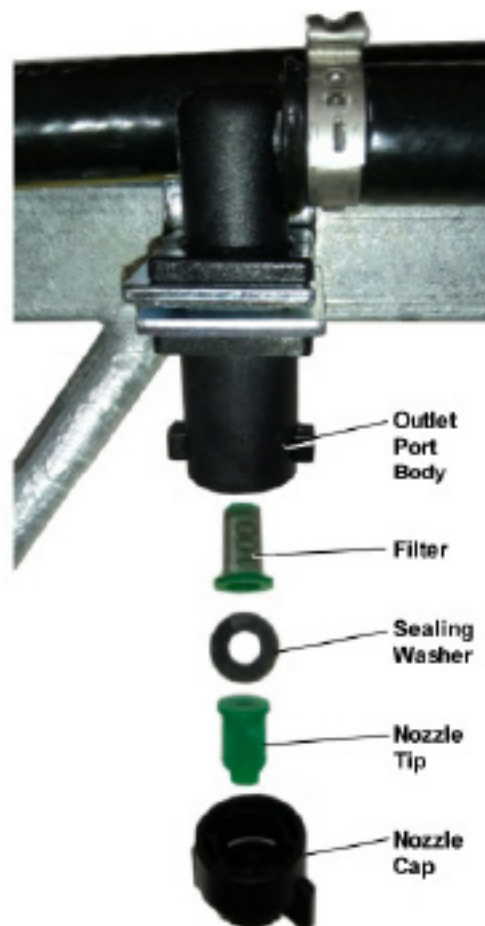

Figure 5 – Adjustable spray nozzle installation

3. Insert the nozzle tip into the nozzle cap, then press in the sealing washer.
4. Push the nozzle cap assembly onto the outlet port body and rotate 90 degrees to lock it into place.
5. Repeat steps 2 to 4 for the remaining two adjustable nozzles.
6. For one of the off-centre end jets, insert the brass nozzle tip into the steel nozzle cap, then press in the sealing washer, refer to Figure 6.

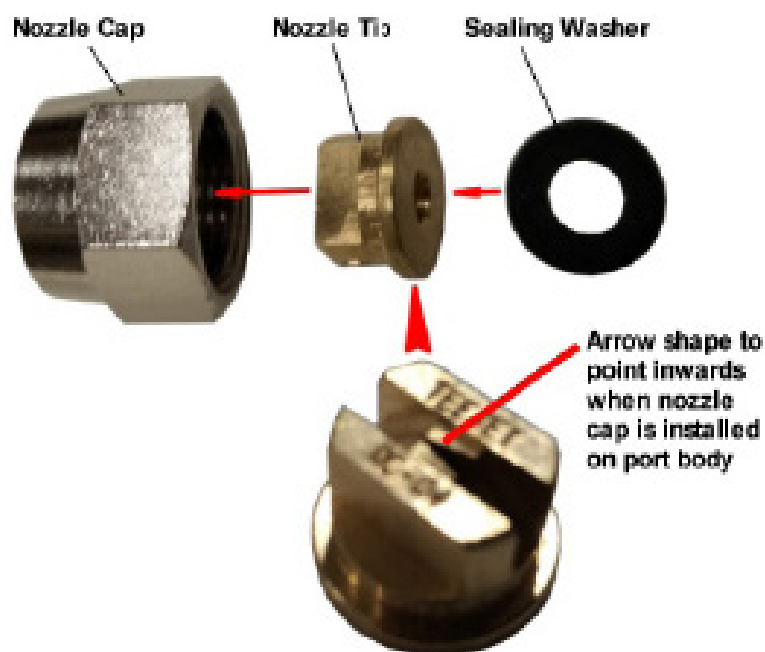

Figure 6 – Off-centre end jet nozzle installation



NOTE: Ensure the brass nozzle tip is orientated such that the arrow shape is pointing inwards.

7. Screw the nozzle cap assembly onto the off-centre end jet port body. The nozzle tip must be orientated such that the open end of the triangle shape orifice is facing outwards, that is, the arrow shape is pointing inwards.
8. Tighten the nozzle cap firmly.
9. Repeat steps 6 to 8 for the second end jet nozzle.
10. At first use, fill the spray unit with water for calibration of the VersatileBoom, refer to the calibration procedure below.

VersatileBoom Calibration

Accurate calibration is an essential element of any spraying function as it ensures that the chemical is applied at the rate specified on the product label. Application in excess of the recommended rate may be dangerous, can damage crops and is uneconomical.

Calibration must be carried out:

- When spraying for the first time with new spray equipment
- At the beginning of each season
- After changes of nozzle tips, spraying pressure or vehicle speed
- After every 100 hectares of spraying

PPE appropriate to the chemicals being used must be worn at all times when calibrating the OnDeck. As a minimum, the PPE should include coveralls, gloves and boots. A face shield and PVC apron are recommended.

Calibration Procedure

Check the label on the chemical container for the application rate and recommended spray nozzle type, refer to Figure 7, which shows the TeeJet AIXR nozzle application chart. To apply a specific rate of chemical to the target surface, work out the:

- total sprayer output,
- travel speed, and
- the swath width.

Using these parameters, the application rate is calculate as follows.

Measure Total sprayer output [L/min]

Set the pressure at the correct level for spraying determined by the type of nozzles. All nozzles used for spraying should be left on. For initial trials, set the pressure regulator at approximately 2 bar and adjust as needed.

1. Fill the spray supply tank with clean water and run the sprayer at the correct pressure with all nozzles operating.
2. Place a measuring jug under first nozzle for one minute, then measure how much water is in the jug.
3. Repeat for all nozzles. Nozzle output should not vary by more than 10%. If it does, the nozzle could be worn or damaged and should be replaced.
4. Add all the jug measurements to find the total sprayer output in litres per minute.

Measure the travel speed [km/h]

The normal speed for spraying with small boom sprayers is 4–10 km/h. The slower the travel, the higher the application rate. Adjust travel speed to suit ground conditions.

1. Measure how many seconds it takes to travel 100 metres with the sprayer attached and half full.
2. Calculate your travel speed by inserting the time in seconds into the following formula: Travel speed (km/h) = distance travelled in metres (say 100m) x3.6 / Time taken (in seconds)

Calculate spray application rate [L/Ha]









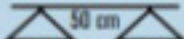

First, measure the swath width in metres. For general broadcast spraying, the swath width is equal to the number of nozzles multiplied by the nozzle spacing. For band spraying the swath width is equal to the total of all the band widths. Calculate the application rate using the following formula:

$$\text{Application rate (L/ha)} = (600 \times \text{total sprayer output (L/min)}) / (\text{swath width (m)} \times \text{travel speed (km/h)})$$

Example: If total sprayer output is 5 L/min, speed is 8 km/h, and swath width is 6m, Application rate = $(600 \times 5 = 62.5 \text{ L/ha}) / (6 \times 8)$









If the application rate is less than specified, increase the pressure and repeat calibration to achieve the correct rate. Once the required rate is achieved, note the following parameters for future reference when using this chemical:

- Nozzle Fitted
- Type (Drop Size)
- Application Rate
- Spray Pressure
- Forward Speed

| Icon | bar | DROPSIZE | LERAP RATINGS | CAPACITY ONE NOZZLE IN L/MIN | l/ha  | | | | | | | | CAP PART NUMBER | | | |
|---|-----|----------|---------------|------------------------------|---|--------|--------|--------|---------|---------|---------|---------|-----------------|---------|-------|-------------|
| | | | | | 5 km/h | 6 km/h | 7 km/h | 8 km/h | 10 km/h | 12 km/h | 16 km/h | 18 km/h | | 20 km/h | | |
|  | 1.0 | XC | - | 0.34 | 81.6 | 88.0 | 94.3 | 100.7 | 107.0 | 113.4 | 119.7 | 126.0 | 132.3 | 138.6 | 144.9 | TH441A-C2LR |
| | 2.0 | C | - | 0.48 | 115 | 124 | 133 | 142 | 151 | 160 | 169 | 178 | 187 | 196 | 204 | |
| | 3.0 | C | - | 0.59 | 142 | 152 | 161 | 171 | 180 | 190 | 199 | 209 | 218 | 228 | 237 | |
| | 4.0 | M | - | 0.68 | 163 | 174 | 185 | 196 | 207 | 218 | 229 | 240 | 251 | 262 | 273 | |
| | 5.0 | M | - | 0.76 | 182 | 194 | 206 | 218 | 230 | 242 | 254 | 266 | 278 | 290 | 302 | |
| | 6.0 | M | - | 0.83 | 199 | 212 | 225 | 238 | 251 | 264 | 277 | 290 | 303 | 316 | 329 | |
|  | 1.0 | XC | - | 0.46 | 110 | 118 | 126 | 134 | 142 | 150 | 158 | 166 | 174 | 182 | 190 | |
| | 2.0 | VC | - | 0.65 | 156 | 167 | 178 | 189 | 200 | 211 | 222 | 233 | 244 | 255 | 266 | |
| | 3.0 | C | - | 0.79 | 180 | 192 | 204 | 216 | 228 | 240 | 252 | 264 | 276 | 288 | 300 | |
| | 4.0 | M | - | 0.91 | 218 | 231 | 244 | 257 | 270 | 283 | 296 | 309 | 322 | 335 | 348 | |
| | 5.0 | M | - | 1.02 | 245 | 259 | 273 | 287 | 301 | 315 | 329 | 343 | 357 | 371 | 385 | |
| | 6.0 | M | - | 1.12 | 269 | 284 | 299 | 314 | 329 | 344 | 359 | 374 | 389 | 404 | 419 | |
|  | 1.0 | XC | ** | 0.57 | 137 | 146 | 155 | 164 | 173 | 182 | 191 | 200 | 209 | 218 | 227 | |
| | 2.0 | VC | ** | 0.81 | 194 | 205 | 216 | 227 | 238 | 249 | 260 | 271 | 282 | 293 | 304 | |
| | 3.0 | C | ** | 0.99 | 238 | 250 | 262 | 274 | 286 | 298 | 310 | 322 | 334 | 346 | 358 | |
| | 4.0 | C | ** | 1.14 | 274 | 287 | 300 | 313 | 326 | 339 | 352 | 365 | 378 | 391 | 404 | |
| | 5.0 | C | ** | 1.28 | 307 | 321 | 335 | 349 | 363 | 377 | 391 | 405 | 419 | 433 | 447 | |
| | 6.0 | M | - | 1.40 | 336 | 351 | 366 | 381 | 396 | 411 | 426 | 441 | 456 | 471 | 486 | |
|  | 1.0 | XC | ** | 0.68 | 163 | 173 | 183 | 193 | 203 | 213 | 223 | 233 | 243 | 253 | 263 | |
| | 2.0 | VC | ** | 0.96 | 230 | 242 | 254 | 266 | 278 | 290 | 302 | 314 | 326 | 338 | 350 | |
| | 3.0 | VC | ** | 1.18 | 283 | 296 | 309 | 322 | 335 | 348 | 361 | 374 | 387 | 400 | 413 | |
| | 4.0 | C | ** | 1.36 | 326 | 340 | 354 | 368 | 382 | 396 | 410 | 424 | 438 | 452 | 466 | |
| | 5.0 | C | ** | 1.52 | 365 | 380 | 395 | 410 | 425 | 440 | 455 | 470 | 485 | 500 | 515 | |
| | 6.0 | M | - | 1.67 | 401 | 417 | 433 | 449 | 465 | 481 | 497 | 513 | 529 | 545 | 561 | |
|  | 1.0 | UC | *** | 0.91 | 218 | 229 | 240 | 251 | 262 | 273 | 284 | 295 | 306 | 317 | 328 | |
| | 2.0 | XC | ** | 1.29 | 310 | 322 | 334 | 346 | 358 | 370 | 382 | 394 | 406 | 418 | 430 | |
| | 3.0 | VC | ** | 1.58 | 379 | 392 | 405 | 418 | 431 | 444 | 457 | 470 | 483 | 496 | 509 | |
| | 4.0 | VC | ** | 1.82 | 437 | 451 | 465 | 479 | 493 | 507 | 521 | 535 | 549 | 563 | 577 | |
| | 5.0 | C | ** | 2.04 | 490 | 505 | 520 | 535 | 550 | 565 | 580 | 595 | 610 | 625 | 640 | |
| | 6.0 | C | - | 2.23 | 535 | 551 | 567 | 583 | 599 | 615 | 631 | 647 | 663 | 679 | 695 | |
|  | 1.0 | UC | *** | 1.14 | 274 | 286 | 298 | 310 | 322 | 334 | 346 | 358 | 370 | 382 | 394 | |
| | 2.0 | XC | *** | 1.61 | 386 | 400 | 414 | 428 | 442 | 456 | 470 | 484 | 498 | 512 | 526 | |
| | 3.0 | VC | ** | 1.97 | 473 | 488 | 503 | 518 | 533 | 548 | 563 | 578 | 593 | 608 | 623 | |
| | 4.0 | VC | ** | 2.27 | 545 | 561 | 577 | 593 | 609 | 625 | 641 | 657 | 673 | 689 | 705 | |
| | 5.0 | C | ** | 2.54 | 610 | 627 | 644 | 661 | 678 | 695 | 712 | 729 | 746 | 763 | 780 | |
| | 6.0 | C | - | 2.79 | 670 | 688 | 706 | 724 | 742 | 760 | 778 | 796 | 814 | 832 | 850 | |
|  | 1.0 | UC | *** | 1.37 | 329 | 342 | 355 | 368 | 381 | 394 | 407 | 420 | 433 | 446 | 459 | |
| | 2.0 | XC | *** | 1.94 | 466 | 481 | 496 | 511 | 526 | 541 | 556 | 571 | 586 | 601 | 616 | |
| | 3.0 | VC | ** | 2.37 | 569 | 585 | 601 | 617 | 633 | 649 | 665 | 681 | 697 | 713 | 729 | |
| | 4.0 | VC | ** | 2.74 | 658 | 675 | 692 | 709 | 726 | 743 | 760 | 777 | 794 | 811 | 828 | |
| | 5.0 | C | ** | 3.06 | 734 | 752 | 770 | 788 | 806 | 824 | 842 | 860 | 878 | 896 | 914 | |
| | 6.0 | C | - | 3.35 | 804 | 823 | 842 | 861 | 880 | 899 | 918 | 937 | 956 | 975 | 994 | |
|  | 1.0 | UC | - | 1.82 | 437 | 451 | 465 | 479 | 493 | 507 | 521 | 535 | 549 | 563 | 577 | TH442-C2LR |
| | 2.0 | XC | - | 2.58 | 619 | 634 | 649 | 664 | 679 | 694 | 709 | 724 | 739 | 754 | 769 | |
| | 3.0 | VC | - | 3.16 | 758 | 774 | 790 | 806 | 822 | 838 | 854 | 870 | 886 | 902 | 918 | |
| | 4.0 | VC | - | 3.65 | 876 | 893 | 910 | 927 | 944 | 961 | 978 | 995 | 1012 | 1029 | 1046 | |
| | 5.0 | VC | - | 4.08 | 979 | 1000 | 1021 | 1042 | 1063 | 1084 | 1105 | 1126 | 1147 | 1168 | 1189 | |
| | 6.0 | C | - | 4.47 | 1073 | 1100 | 1127 | 1154 | 1181 | 1208 | 1235 | 1262 | 1289 | 1316 | 1343 | |
|  | 1.0 | UC | - | 2.28 | 547 | 563 | 579 | 595 | 611 | 627 | 643 | 659 | 675 | 691 | 707 | |
| | 2.0 | UC | - | 3.23 | 775 | 792 | 809 | 826 | 843 | 860 | 877 | 894 | 911 | 928 | 945 | |
| | 3.0 | XC | - | 3.85 | 948 | 966 | 984 | 1002 | 1020 | 1038 | 1056 | 1074 | 1092 | 1110 | 1128 | |
| | 4.0 | VC | - | 4.56 | 1094 | 1113 | 1132 | 1151 | 1170 | 1189 | 1208 | 1227 | 1246 | 1265 | 1284 | |
| | 5.0 | VC | - | 5.10 | 1224 | 1244 | 1264 | 1284 | 1304 | 1324 | 1344 | 1364 | 1384 | 1404 | 1424 | |
| | 6.0 | VC | - | 5.59 | 1342 | 1363 | 1384 | 1405 | 1426 | 1447 | 1468 | 1489 | 1510 | 1531 | 1552 | |

NOTE: Always double check your application rates. Tabulations are based on spraying water at 21°C.

DROPLET SIZE CATEGORIES

| | | | | | | | |
|---|---|---|---|---|---|---|---|
|  |  |  |  |  |  |  |  |
| XF | VF | F | M | C | VC | XC | UC |
| EXTREMELY FINE | VERY FINE | FINE | MEDIUM | COARSE | VERY COARSE | EXTREMELY COARSE | ULTRA COARSE |

Droplet size may vary with nozzle capacity, spray angle and spray pressure.

Figure 7 - AIXR Application Chart

VersatileBoom Operation



NOTE: Before commencing spraying, plan the work effectively to minimise potential contamination of adjacent areas.

Operation of the VersatileBoom is conducted as follows:



CAUTION: Do not spray in windy conditions, where spray drift contamination may occur. Spray drift can be reduced by lower nozzle height, lower pressures or by fitting larger nozzles.

1. Wind direction and speed must be taken into account, as windy conditions may endanger the operator or damage to adjacent non-target vegetation. Avoid spraying on hot and sunny days or when wind speed exceeds 6.5km/h.



NOTE: Standard mounting height for the spray nozzles is 500mm above ground surface.

2. Wind drift can be reduced by lowering the VersatileBoom such that the nozzles are closer to the ground, using lower pressure or by fitting larger nozzles.
3. Check the calibration of the VersatileBoom spray nozzles for correct delivery of product; the calibration procedure is described above.
4. Set the required spray selection by opening or closing the individual control valves on the spray lines, refer to Figure 8.

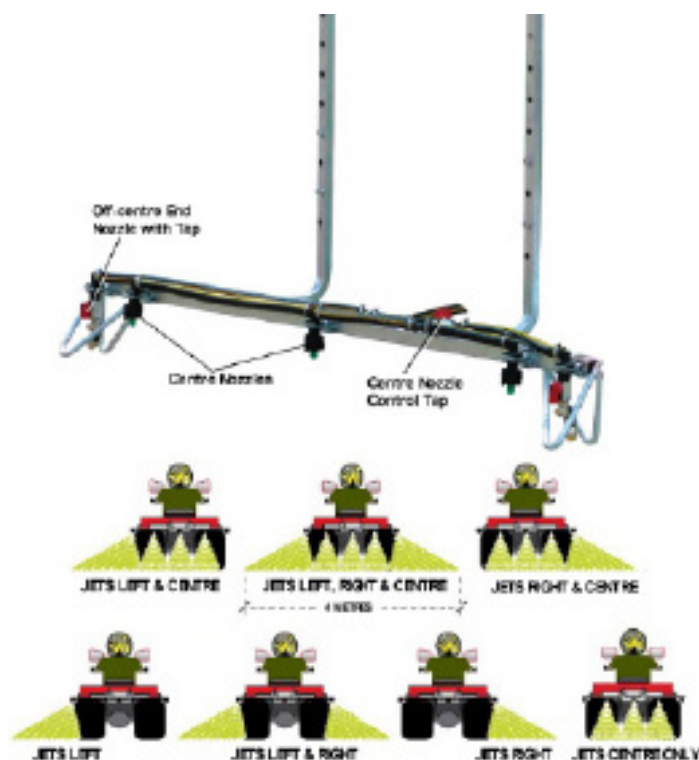

Figure 8 – VersatileBoom Spray Configurations

5. Position the vehicle at the starting point of the operations area.
6. Start the pump system and commence driving the vehicle at the speed determined during calibration to achieve the required spray outcome.

Clean-up and Decontamination

After use, the spray equipment must be thoroughly decontaminated inside and outside – including the pump, hoses and VersatileBoom – to avoid damage to crops from any harmful spray residues. Decontamination also prevents spray system corrosion and abrasion.

Cleaning the system should be undertaken at a carefully chosen site, away from any risk of spillages draining into watercourses or into environmentally sensitive areas.

The recommended decontamination procedure is as follows:



WARNING: Suitable PPE must be worn by the operator when cleaning and decontaminating the VersatileBoom. Follow the instructions provided with the chemicals or the applicable Safety Data Sheet.



WARNING: Ensure the cleaning area is in an open, well ventilated space, and any flushing water is captured to prevent runoff into watercourses or into environmentally sensitive areas.

1. After spraying operations are complete, drain any residual fluid from the tank. Capture and dispose or store any fluid in accordance with environmental and work safety requirements.
2. Rinse out the tank with several changes of water, plus a recommended cleaning fluid.
3. Operate the spray unit with clean water using the spray boom, to ensure no chemical residue remains.
4. Nozzles, nozzle filters, nozzle caps and sealing washers should be cleaned by soaking in water, brushing with a nozzle brush and allowed to dry. Do not blow through the nozzles or use wire or pins to clear any blockages.

If the VersatileBoom is to be stored for an extended period, thoroughly clean and decontaminate it as described above. Ensure it is allowed to dry, all lines empty and not pressurised then store it in a well ventilated area.

Maintenance

Your VersatileBoom requires minimal maintenance but regular cleaning and checks will ensure safe and reliable service over its lifetime. Periodic checks and inspections will identify any potential issues, enabling timely rectification and minimising downtime.

Periodic Checks

The following tasks are to be conducted in accordance with each of the schedules. All scheduled tasks are to be undertaken concurrently. For example, at the three month maintenance interval, all tasks listed are to be undertaken, in addition to the daily, weekly and monthly tasks.

1. Clean the unit and inspect it for any signs of damage or wear.
2. Check all fittings are firmly secured, tighten if necessary.
3. If the VersatileBoom is to be stored for an extended period, thoroughly clean and decontaminate the unit as described above. Ensure it is allowed to dry and all lines empty and not pressurised then store it in a well ventilated area.

Maintenance Schedule

The following tasks are to be conducted in accordance with each of the schedules. All scheduled tasks are to be undertaken concurrently. For example, at the three month maintenance interval, all tasks listed are to be undertaken, in addition to the daily, weekly and monthly tasks.



NOTE! Maintenance is important. Keep a record of all maintenance tasks conducted on the VersatileBoom.

TTi recommends photocopying these schedules in order to keep a detailed log of all maintenance tasks. A copy of these schedules will be required to support any warranty claim.

Daily tasks

The following tasks are to be undertaken daily, or prior to each use, of the VersatileBoom.

| No. | Task | Notes |
|-----|---|--------------------------|
| 1 | Inspect the VersatileBoom for any signs of damage or wear | Clean, repair or replace |
| 2 | Check security of spray nozzles and hoses | Tighten as required |

Weekly Tasks

The following tasks are to be undertaken each week or 10 operating hours, whichever occurs first.

| No. | Task | Date | Signed |
|-----|--|------|--------|
| 1 | All Daily tasks | | |
| 2 | Check for any signs of leaks in hoses and fittings | | |
| 3 | Clean mesh filters and nozzle tips | | |

Monthly tasks

The following tasks are to be undertaken each month or 20 operating hours, whichever occurs first.

| No. | Task | Date | Signed |
|-----|--|------|--------|
| 1 | All Daily and Weekly tasks | | |
| 2 | Check securing system used to fastener unit to vehicle | | |

Three Monthly tasks

The following tasks are to be undertaken every three months or 50 operating hours, whichever occurs first.

| No. | Task | Date | Signed |
|-----|-------------------------------------|------|--------|
| 1 | All Daily, Weekly and Monthly tasks | | |

Six Monthly tasks

The following tasks are to be undertaken every six months or 100 operating hours, whichever occurs first.

| No. | Task | Date | Signed |
|-----|--|------|--------|
| 1 | All Daily, Weekly, Monthly and 3-Monthly tasks | | |

Twelve Monthly tasks

The following tasks are to be undertaken every twelve months or 200 operating hours, whichever occurs first.

| No. | Task | Date | Signed |
|-----|---|------|--------|
| 1 | All Daily, Weekly, Monthly, 3-Monthly & 6-Monthly tasks | | |

Twelve Monthly tasks

The following tasks are to be undertaken every 24 months or 500 operating hours, whichever occurs first.

| No. | Task | Date | Signed |
|-----|---|------|--------|
| 1 | All Daily, Weekly, Monthly, 3-Monthly, 6-Monthly and 12-Monthly tasks | | |

Risk Assessment

| Task | Hazard | Risk | Control Measure/Mitigation |
|---|---|--------|--|
| Check weather conditions | Manual handling; slips, trips or falls | Low | <ul style="list-style-type: none"> Wear PPE as per chemical requirements SDS – coveralls, gloves, safety footwear, glasses & respirator Follow safe manual handling techniques: don't lift on your own if >20kg, bend knees & keep back straight. |
| Mix chemicals (if applicable) and fill spray tank | As above, spray drift, chemical spillage, emission of vapours or flammability: weather, untrained visitors | Medium | <p>As above</p> <ul style="list-style-type: none"> User trained in relevant chemical mixing & administration course, e.g, Chem Cert; Follow relevant Environmental Protection Authority requirements; Fire extinguisher nearby; Keep visitors away from job location unless wearing full PPE. |
| Using Spray Unit | As above; loss of load; heat & cold; noise; exceed load limit of vehicle; hose entanglement; exhaust fumes; terrain & slope | High | <p>As above</p> <ul style="list-style-type: none"> wear clothes to suit heat & cold; Wear hearing protection if noise >85 dBa; Follow the manufacturer's safe operation instruction for the vehicle and the spray unit Don't overload - water weighs 1kg for every 1 litre Secure load to vehicle. |
| Clean up, maintenance & storage | As above | Low | <p>As above;</p> <ul style="list-style-type: none"> Continue to wear PPE for clean up; Store unit in a dry, well ventilated area. |

Warranty

Your rights under the law

Our goods come with guarantees that cannot be excluded under the Australian Consumer Law.

You are entitled to a replacement or refund for a major failure and compensation for any other reasonably foreseeable loss or damage. You are also entitled to have the goods repaired or replaced if the goods fail to be of acceptable quality and the failure does not amount to a major failure.

About this document

This document sets out the terms of the defects warranty that we offer to retail purchasers of our goods, including components, parts, and accessories (referred to as “products” in this document). We offer this defects warranty in addition to the consumer guarantees referred to above. Nothing in this document excludes or reduces your rights under those consumer guarantees.

What this warranty covers

This warranty covers defects in materials or workmanship (or both) which are found to be present in our products, other than the defects in the parts and components listed below.

What this warranty does not cover

This warranty does not cover defects or damage caused by your negligence, your failure to follow instructions (including incorrect assembly or mounting by you), or the improper use, maintenance, or abuse of the products.

This warranty does not cover engines, gearboxes, pumps, or regulators. These come with separate warranties from their manufacturers. By offering this defects warranty, we do not assume any additional obligations or liability on behalf of those manufacturers beyond what we must do to comply with the consumer guarantees referred to above.

How long this warranty lasts for

Except in the case of products used for rental purposes, the period of our defects warranty is as follows for our various products:

| | |
|--------------------------------------|----------|
| Tanks (non-diesel), excluding frames | 25 Years |
| Steel frames | 5 Years |
| Other TTi Manufactured Components | 1 Year |

This warranty lasts for one year from the date of your retail purchase of the products, unless it is used for rental purposes, in which case this warranty is limited to 90 days.

What we will do if you make a claim under this warranty

If you make a claim under this warranty, we will consider it in good faith. If we agree that the products are covered by this warranty and are defective, we will either (at our option) repair or replace them without charge to you.

What you must do (and not do) to entitle you to a claim under this warranty

You must be able to provide proof of purchase, either by providing details of your warranty registration or a purchase receipt.

You must not repair or modify (or allow the repair or modification of) the products without prior authorisation from us. Further, you must not use any non-genuine parts with the products. Doing any of these things will void this defects warranty.

How to make a claim under this warranty

If you believe that you have a claim under this warranty, please contact your reseller, or contact us using the following details:

| | |
|--------------------------|---|
| Name: | Trans Tank International |
| Postal Address: | PO Box 137 Nathalia, VIC, 3683 |
| Physical Address: | Murray Valley Highway, Nathalia, VIC, 3638 |
| Phone: | 1800 816 277 |
| Email: | ProductSupport@tti.com.au |

You must make the defective products available for inspection by returning them to us, and (if requested to do so) by making them available for inspection by us on site beforehand. You must ensure that the products are made safe for transportation and inspection, including by cleaning them thoroughly to remove any chemical residues. All returned products must be accompanied by a completed Return Goods Note. Please contact us using the details displayed above for a copy of this document.

Who is responsible for expenses for claims made under this warranty

You are responsible for any expenses associated with the warranty claim, including transportation, charges made for service calls, and clean-up time.



TranTank[®]
INTERNATIONAL



Scan to view our PDF
Handbook online

1800 816 277

sales@tti.com.au

PO Box 137, Nathalia, VIC, 3638

Murray Valley Hwy, Nathalia, VIC 3638

Proudly Built By:

Signature

Date

Quality Checked By:

Signature

Date

www.tti.com.au